

# Gerber Solara ion<sup>X</sup>™

## Site Requirements

The information in this document is extremely important because it specifies the requirements a facility must meet in order to properly install the Gerber Solara ion<sup>X</sup>. It is also important that the Site Preparation Checklist (the last page of this document) is completed and returned to your local distributor so that they can schedule the installation.

Customer Name: \_\_\_\_\_

Shipping Address: \_\_\_\_\_

Phone: \_\_\_\_\_ Fax: \_\_\_\_\_

Contact Name(s): \_\_\_\_\_

Service Engineer: \_\_\_\_\_

### Loading dock requirements

Upon meeting the customer, begin the pre-site inspection from the loading dock. Follow the path that will be used to bring the system from the loading dock to the proposed location. Answer the following questions and refer to the attached layout diagrams.

- ◆ Loading dock height (from ground to dock floor): \_\_\_\_\_
- ◆ Loading dock width: \_\_\_\_\_
- ◆ How will the system be removed from the delivery vehicle? \_\_\_\_\_
- ◆ Is a forklift available? Yes / No
- ◆ What is the narrowest doorway or aisle the system must pass through to get to its permanent location? \_\_\_\_\_
- ◆ Level the system will be installed on (Basement, 1<sup>st</sup> floor, 2<sup>nd</sup> floor, etc.): \_\_\_\_\_
- ◆ Method of movement to upper floors: \_\_\_\_\_ Elevator: \_\_\_\_\_
- ◆ Size and capacity of elevator: \_\_\_\_\_ Riggers: \_\_\_\_\_

**The customer is responsible for providing appropriate equipment for unloading and moving the system into place. If a loading dock is not available, you must have a forklift capable of unloading the system from the back of the delivery truck. If this equipment is not available or the system requires movement to an upper floor, riggers or special equipment will be required. This is the responsibility of the customer.**

## ☑ Labor requirements

One person, capable of lifting 50 lbs. (23 kg) must be available to assist the technician on the first day of installation. It is the customer's responsibility to ensure that this person is on hand. If on-site staff is not available, contact local temporary agencies or moving companies to hire labor.

## ☑ Power requirements

Gerber recommends that you leave the Gerber Solara ion powered on **AT ALL TIMES**. Do not turn the printer off, even for extended periods of down time.



*Note: If you choose to turn the printer off some ink may leak from the print heads.*

230 VAC +/- 10% at 50-60Hz, single phase, 15 Amps continuous

### **Domestic**

The Gerber Solara ion<sup>X</sup> power cord comes with a NEMA 6-15P plug and requires the matching NEMA 6-15R receptacle.



### **International**

The Gerber Solara ion<sup>X</sup> comes with a European CEE 7/7 plug and requires the matching CEE 7 receptacle. These connectors can be changed to meet local standards.

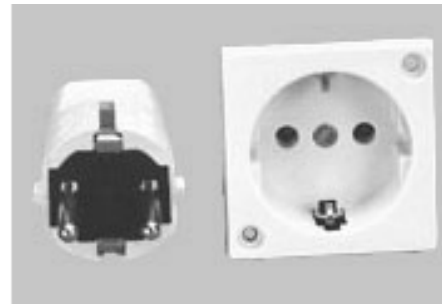

**WARNING:** Make sure to connect the power cable only after all of the steps of the installation procedure have been completed.

## ☑ Operating requirements

The Gerber Solara ion<sup>X</sup> should be installed in a relatively clean environment, free of the dust and dirt from routing or sandblasting for example. Gerber recommends setting up in an air-conditioned environment in order to maintain constant temperature and humidity. **Be sure to allow the equipment, inks and media to reach and remain at room temperature before printing.** The ambient environment should meet the following conditions:

## Ambient conditions

The operating environment must meet the following conditions:

- ◆ **Temperature: 65°F to 75°F (18.5°C to 24°C)**
- ◆ **Humidity: 40% - 60%, non-condensing**
- ◆ Ventilation: no special ventilation required
- ◆ Operating altitude: 8,000 feet (2,438m) or less
- ◆ Avoid using printer near open windows, outside doors, or heating/cooling systems
- ◆ Protect printer and ink pouches from moisture, dust, drafts, and direct sunlight

## Storing GerberCAT™ inks

GerberCAT inks have a shelf life of approximately twelve months from date of manufacture when stored as recommended. Ink pouches should be stored out of direct sunlight and other lighting sources.

- ◆ Temperature: 41° F to 86° F (5° C to 30° C)
- ◆ Humidity: 30% - 70% non-condensing



*Note: The guaranteed term of ink is 12 months from date of manufacture when it is kept or used without exposing air at 77°F (25°C).*

## Material storage



See material-specific documentation for recommended handling and storage requirements.

General material storage and handling suggestions follow:

- ◆ Material should not be stored on the floor.
- ◆ Do not discard the original packaging. Use the box or plastic bag for material storage.
- ◆ Store material in a dry environment avoiding high temperature, high humidity, and direct sunlight.
- ◆ The size of the material can change according to the temperature and/or humidity changes of the working environment. Before using the material, “normalize” it in the working environment.
- ◆ Printing before the material is acclimated to the working environment may cause print head strikes due to material distortion, and affect output print quality
- ◆ Do not use creased, damaged, torn, curled, bowed, or warped material.
- ◆ Material may have a printable side and a non-printable side. If you print on a non-printable side, blurring may occur.
- ◆ Do not touch the printable side of material before printing. Moisture or oil from hands can affect the printing quality.
- ◆ Do not leave material loaded in the roll-to-roll unit of the printer for an extended period of time. The pinch wheels may damage it or the material may curl resulting in misalignment, jams, or decreased printing quality.

## ☑ Shipping and clearance specifications

The Gerber Solara ion<sup>x</sup> comes in several shipping crates that are conveniently sized to fit through standard 36" (91cm) door openings. See the following list for **crated** specifications for the Gerber Solara ion<sup>x</sup>.

	Crate #1	Crate #2	Crate #3
<b>Contents:</b>	Table Kit with Hardware Table Extrusions (2) Table Legs (2) Skirt Kit (3 pieces) Cable Track Roll-to-Roll Platen Maintenance Shield Assy.	Gantry Assembly Ink Drawer Box Electrical Box Fans and Baffles Accessory Boxes	Roll-to-Roll Support Assembly
<b>Width:</b>	35.25" (89cm)	35.25" (89cm)	35.25" (89cm)
<b>Length:</b>	140" (356cm)	119" (302cm)	75.5" (192cm)
<b>Height:</b>	78" (198cm)	52" (132cm)	32" (81cm)
<b>Weight:</b>	1,100 lbs. (499kg)	850 lbs. (386kg)	280 lbs. (127kg)
			

## ☑ Work area requirements

The following chart describes the unpacked and assembled specifications for the Gerber Solara ion<sup>x</sup> printer.

Width:	Length:	Height:	Weight:
104 in (264cm)	148 in (376cm)	52 in (132cm)	~ 1,000 lbs. (454kg)

P81126A

© 2008- Gerber Solara ion<sup>x</sup> and GerberCAT are trademarks of Gerber Scientific Products.

# Gerber Solara ion<sup>x</sup> Layout diagrams

When selecting a location, **Gerber recommends an additional border around the printer of at least 3 feet (1 m)** for loading and unloading material and large prints. Plan additional space for storing rolls of media and ink cassettes.

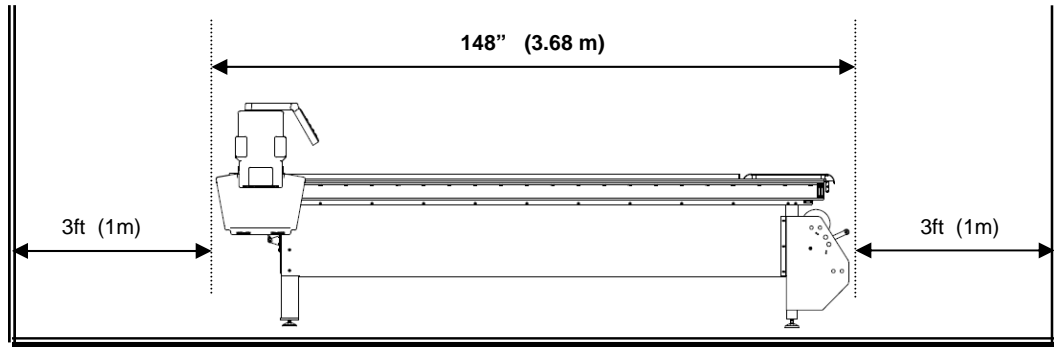
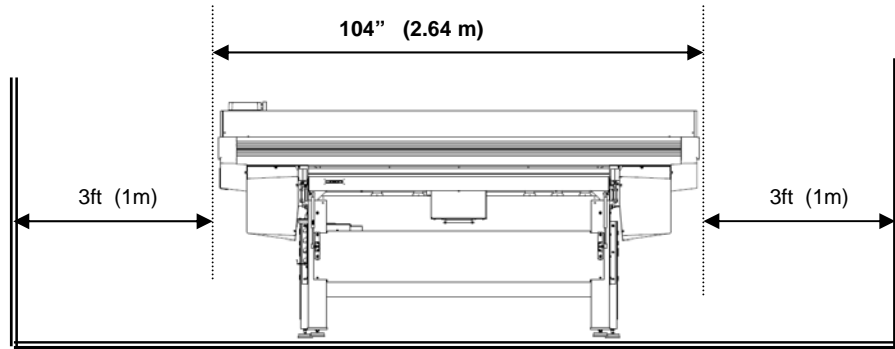

**Power connection (P)**

Located under table. 14ft (4.25m) cable included.

**Network connection (N)**

Located next to on/off switch. Ethernet cable included.

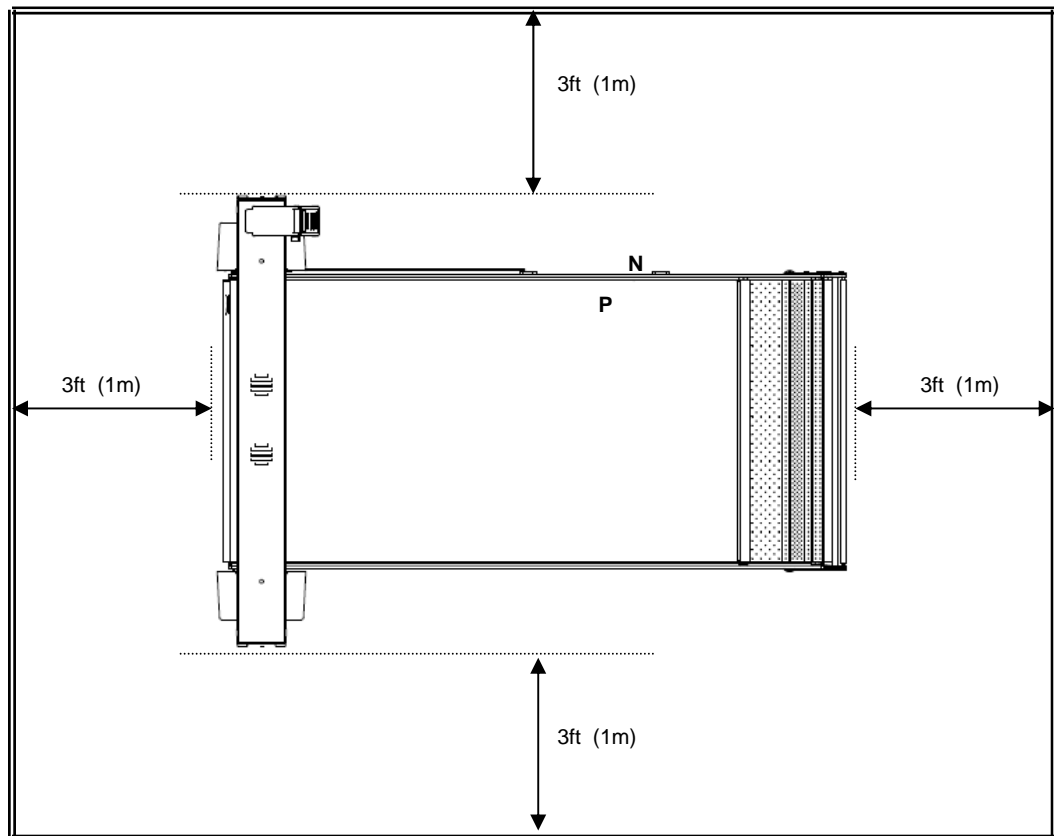

# Gerber Solara ion<sup>x</sup> Site Preparation Checklist

In order to expedite the scheduling of the Gerber Solara ion<sup>x</sup> installation, please complete this checklist and return it to your local distributor.

Description	Complete
<p><b>Ambient conditions requirement:</b>                      The operating environment must meet the following <b>strict</b> conditions:                      Temperature: <b>65°F to 75°F (18.5°C to 24°C)</b>                      Humidity: <b>40% - 60%, non-condensing</b>                      Operating altitude: <b>8,000 feet (2,438m) or less</b></p>	<p><input type="checkbox"/>  <input type="checkbox"/>  <input type="checkbox"/></p>
<p><b>Power requirements for the Gerber Solara ion<sup>x</sup>:</b>                      230 VAC +/- 10% at 50-60Hz, single phase, 15 Amps continuous.                      A licensed electrician will install the required receptacle prior to installation.</p>	<p><input type="checkbox"/>  <input type="checkbox"/></p>
<p><b>Weight and clearance requirements:</b>                      Does not have a loading dock but has a forklift to take the Gerber Solara ion<sup>x</sup> (1,000 lbs. (454kg)) off the carrier's truck.                      Has a loading dock and a forklift or pallet jack to take the Gerber Solara ion<sup>x</sup> (1,000 lbs. (454kg)) off the carrier's truck.                      Does not have a dock or a forklift or pallet jack and will be hiring riggers to facilitate the delivery and installation of the Gerber Solara ion<sup>x</sup>.                      The outside doorway into the facility is at least 36" (91cm) wide.                      Interior corridors and doorways are at least 36" (91cm) wide. (Wider widths are needed for turning radius)                      The path from the loading dock to the printer's permanent location is free and clear of obstructions.                      Business location/area.                      Residential location/area.</p>	<p><input type="checkbox"/>  <input type="checkbox"/>  <input type="checkbox"/>  <input type="checkbox"/>  <input type="checkbox"/>  <input type="checkbox"/>  <input type="checkbox"/>  <input type="checkbox"/></p>
<p><b>Labor requirements:</b>                      One person capable of lifting 50 lbs. (23 kg) will be on hand to assist the technician on the first day of installation.</p>	<p><input type="checkbox"/></p>
<p><b>Work area and operating requirements:</b>                      Has sufficient work area (3 ft (92cm)) clearance on all sides of the printer.                      The floor is level and free of debris.                      There is a clean area for storage of media. Media should not be stored on the floor.                      There is an enclosed storage area for ink pouches that is out of direct sunlight or other lighting sources including fluorescent and halogen.                      Facility meets the environmental and cleanliness requirements. (Specifically temperature)                      Will store the shipping crates in its original condition for use during reshipment.</p>	<p><input type="checkbox"/>  <input type="checkbox"/>  <input type="checkbox"/>  <input type="checkbox"/>  <input type="checkbox"/>  <input type="checkbox"/></p>
<p><b>Warranty acceptance:</b>                      I have read and understand the Gerber Solara ion<sup>x</sup> warranty and accept the terms and conditions.</p>	<p><input type="checkbox"/></p>

Customer Name: \_\_\_\_\_ Signature: \_\_\_\_\_

Title: \_\_\_\_\_ Date: \_\_\_\_\_

Company name: \_\_\_\_\_ Phone: \_\_\_\_\_

Installer Name: \_\_\_\_\_ Signature: \_\_\_\_\_